

# STUDY ON STRUCTURAL ANALYSIS AND DESIGN OF RCC BIN

**M.Kishore<sup>1</sup> M.Sanjeev Pandi<sup>1</sup>**

U.G. Student, Department of Civil Engineering,  
Akshaya College of Engineering & Technology,  
kinathukadavu.  
Kishoremh11@gmail.com

**P.A.Edwin fernando<sup>2</sup>**

Assistant Professor, Department of Civil Engineering  
Akshaya College of Engineering & Technology,  
kinathukadavu.  
civiledwin@gmail.com

**Abstract-** Storage is one of the essential and vital stages between the marketing and consumption phases. Reinforced cement concrete (RCC) is an ideal structural material for building of permanent bulk storage facilities. RCC Bin can be flat bottom type or hopper bottom type. Though flat bottom bins can be built more easily than hopper bottom bins but it is desirable that bottom is self cleaning. It is due to this reason that hopper bottom bins are preferred. Specified the various parameters such as height of bin, diameter of bin, properties of the material to be stored ( angle of repose and density), grade of steel, grade of concrete, the number of supports, and the components are designed. For every single case, support numbers have been varied in multiple of 2, starting from 4say4, 6, 8, 10, 12etc. Conforming to the usual practice, the supports are assumed to be equally spaced alongside the periphery. For the designed components (ring girder dimensions, column cross-section, thickness of wall ), depending upon height &diameter of the bins, mass matrix and influence coefficient matrix is then generated. The, parameters such as fundamental natural frequency and other frequencies in first 3 modes for bin full and bin empty conditions have been computed and the normalized Eigen values have been computed corresponding to first 3 modes. Further, dynamic & static analysis of bins has been carried out by taking elements at 2m interval both in bin (full & empty) conditions. Then the values of natural frequencies and elemental matrices along with normalized mode shape values are used in carrying out dynamic analysis.

## I.INTRODUCTION

### 1.1 General

Food grains form an important part of the vegetarian Indian diet. The grain production has been steadily increasing because of advancement in production technology, but the inappropriate storage results in high losses in grains. According to World Bank Report (1999), post-harvest losses in India amount to 12 to 16 million metric tons of food grains per annum, an amount that the World Bank stipulates could nourish one-third of India's poor. The financial value of these losses amounts to more than Rs 50,000 crores per year (Singh, 2010). Natural contamination of food grains is greatly influenced by environmental

factors such as type of storage structure, temperature, pH, moisture, etc (Sashidhar et al, 1992). Length and purpose of storage, types of structure used, grain treatment (eg parboiling) and pre-storage practices are all main variables affecting storage losses. The value of these regional and crop variations immediately determines certain necessary characteristics of crop storage research (Greeley, 1978).During storage, quantitative as well as qualitative losses occur because of rodents, micro-organisms, and insects. A huge number of insect pests have been reported to be associated with stored grains. The occurrence & numbers of stored grain insect pests are directly related to climatic and geographical conditions (Srivastava, and Lal 1985). Virtually all species have remarkably high rates of multiplication and within one season may destroy 10-15% of the grain and contaminate the rest with undesirable flavors and odors. Insect pests as well play a essential role in transportation of storage fungi (1990, Sinha and Sinha).The major construction materials for storage structures in rural areas are stones, plant materials ,mud, and bamboo. They are neither rodent-proof, nor secure from insect and fungal attack. On average, out of a total 6% loss of food grain in such storage structures, with reference to half is due to insects and fungi, and half to rodents. Various research and development organizations in India have identified some proven, age-old structures from certain areas of the country and based on these, some improvised storage structures have also been developed and recommended for use at farmer level.

### 1.2 Definition

RCC BIN is a bulk storage structure. It is used to store large quantities of materials like grains, coals etc.

### 1.3 Applications of Bin

- BIN can be used in the industry to store coals.
- It is used to store food grains.

#### 1.4 Objective of Investigation

The purpose of this project is to introduce Grain Storage Bins in India to avoid grain wastage. Grain storage facilities take many forms depending on the quantity of grain to be stored, the location of the store and the purpose of storage. In general grain for food purposes to be stored in containers provides some protection against insects and helps prevent quality deterioration. The requirements for a good storage system include Prevention of moisture re-entering the grain after drying, Protection from rodents, birds and insects. Easiness of loading and unloading, Effective use of space and ease of maintenance & management.

The project aims to develop strategies that improve food security of poor households through increased availability and improved quality of cereals and pulse foods and better access to markets. Particularly, it seeks to check the institutional arrangements associated with community-managed storage and distribution systems, in addition to solve the technical requirements dictated by these systems for the storage of dry-land crops, and to draw wider lessons concerning decentralized, village-based approaches to the provision of food security.

The project is focused on providing technical support to village-level food security project. The project seeks to enhance the food security of vulnerable men and their households through group-based activities that enable women to access productive resources through the cultivation of unplanted lands. This group creation will then be used as an institutional basis for storage, supply and sale of commodities, in addition to other activities that can contribute to livelihoods of these households. A menu of suitable storage arrangements are to be selected and tested, that give effective safety against serious grain deterioration.

- The building should be elevated and away from the moist places in the house;
- So far as possible, the structure should be airtight, still at loading and unloading ports.
- Rodent-proof materials should be intended for construction of rural storages;
- The area surrounding the building should be clean to reduce the insect breeding;
- The building should be plastered with an impervious clay layer to keep away from termite attack, or attack by other insects.

## II LITERATURE REVIEW

A.H.Askari and A.E. Elwi (1988). "Numerical Prediction of Hopper Bin Pressures"

In this paper a simple iterative technique is developed to model bulk material behaviour when stored in bin-hopper arrangements. The technique is tested and found valid in the sense that it captures the overall behaviour as well as critical design pressures. The numerical study of wall pressures generated by bulk materials stored in hopper-bin combinations is presented. Emphasis is positioned on incipient flow type pressures on inclined hopper walls. The method used incorporates a Drucker-Prager-type elastic, entirely plastic model for an assumed granular bulk material and Coulomb-type friction for the boundary interface. A double-layered iterative scheme with a relaxation function is used to model proper contact friction interfaces with material nonlinearities. Throughout the numerical investigation they predict the hopper bin pressures.

J.G. Teng, J.M. Rotter, "Buckling of rings in column-supported bins and tanks"

The numerical results from the closed form solution were compared with finite element shell analysis, through the analysis stress non-uniformity on the buckling predictions is demonstrated

Theories for the out-of-plane buckling of rings under the same circumferential compression are well recognized. Still these theories are not applicable to rings in column-supported bins where the circumferential stress in the ring varies considerably over the cross-section and around the circumference.

This one deals with the out-of-plane buckling of annular plate rings in column-supported bins and tanks. The stress distributions in such rings are first examined by a finite element shell analysis. A closed-form result for the buckling of rings under non-uniform circumferential stresses is then derived. Numerical results from the closed-form solution are compare with those from a finite element shell buckling analysis, and close agreement is found. Then the important effect of stress non-uniformity on the buckling predictions is established. Finally, simplified equations are given which are appropriate for structural design purposes, and which closely model the predictions of the more exact solution.

Mark E. Killion (1985). "Design Pressures in Circular Bins"

This article has provided some within reach into the design pressures in circular bins. It was revealed that shallow bins ( $H < 1.5D$ ) can be designed by static pressures obtained from the

Coulomb equations. For shallow bins, the properties of the stored material be able to estimated from design charts.

Design pressures in the circular bins, which have been of concern in latest years are examined. Shallow bin pressures are differentiate from deep bin pressures. Furthermore, deep bin pressures are examined for mass flow and funnel flow conditions. Pressures because of outside temperature variations are examined.

### III Auto CAD Drawing

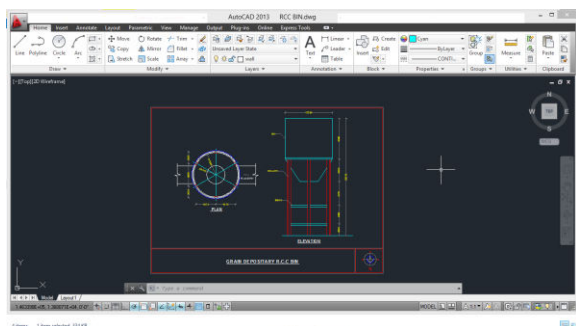

## IV DESIGN CONSIDERATIONS

### 3.1 Type Of Flow (Funnel Flow):

Funnel flow involves the formation of a flow channel aligned with the bin outlet, surrounded by a region in which the material initially stands still. During bin discharge, if the material is not very cohesive, the highest part next to the walls progressively crumbles, feeding the centre channel. If the material is very cohesive, the bin may stop emptying owing to the formation of an empty centre channel surrounded by nonmoving material. In discharge from a bin with funnel flow, the material does not all move together, which makes the material flow at the outlet and the bulk density of the resulting particulate bed change. Funnel flow. Progressively in the course of the operation, even when the bin has almost completely emptied, material is still left inside, which has not yet moved. This solid, accumulated in the bin's dead spaces, not only lowers bin effective capacity but can even become unserviceable if its properties change with time (by drying, oxidizing, etc.). Furthermore, this type of flow makes the negative effects caused by any in homogeneity of the stored powder, owing to possible size segregation during filling, more pronounced.

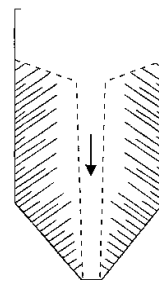

Grain flow through funnel

### 3.2 Bin Consideration

This involves determining the maximum angle that the bin walls form with the vertical in the discharge zone,  $\theta$ , and the smallest outlet size,  $D$ , at which bin discharge occurs by uninterrupted mass flow (Figure).

Preliminary considerations, Outlet obstructions, Bin outlet size must be sufficiently large to keep from becoming obstructed during discharge. This phenomenon can stem from doming if the powder is cohesive, or from blocking up as a result of structures forming if the particles are sufficiently large.

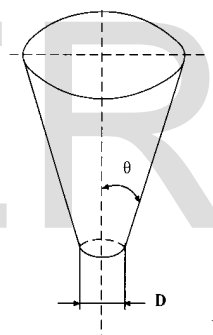

Design Variables

### 3.3 Load Considerations

#### 3.3.1 Bin Loads

Bin Load. - Three types of loads are caused by the material stored in a bin as shown in below.

- Horizontal pressure or horizontal load ( $P_{ia}$ ) acting on the sidewalls of the bin,
- Vertical pressure or vertical load ( $P_v$ ) acting on the area of the bin during filling,
- Frictional wall pressure or frictional wall load ( $P_w$ ) introduced into the side walls through wall friction.

IV LOAD CALCULATIONS

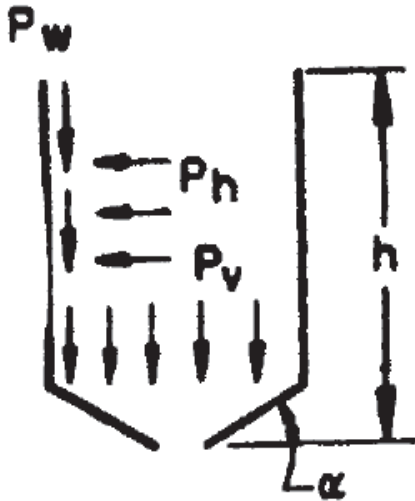

3.4 Bin Loads Owing To Granular Materials

3.4.1 Normal Filling and Emptying Condition:

Maximum pressure or load - The utmost values of the longitudinal (pressure or load) on the wall (Ph), the vertical (pressure or load) on the longitudinal cross section of the material stored (Pv) and due to friction (Pw), need to find the lateral pressure shift to the wall per unit area as follows (IS:4995 Part 1-1974)

Name of Pressure	During Filling	During Emptying
Maximum $P_w$	$WR$	$WR$
Maximum $P_h$	$\frac{WR}{\mu_f}$	$\frac{WR}{\mu_e}$
Maximum $P_v$	$\frac{WR}{\mu_f \lambda_f}$	$\frac{WR}{\mu_e \lambda_e}$

$P_v$  and  $P_w$  cannot be highest at the same time. Therefore in hopper bottom design, highest  $P_t$  should be deemed and this significant value will be the highest  $P_v$  at the specific depth Multiplied to the area of cross section of bin system. The highest  $P_w$  (emptying) shall be finding when the side walls need to be designed at specific

Depth as;

$$\sum_0^Z P_w = \pi DWR \left( Z + \frac{1}{\lambda_{oe}} \cdot e^{-Z/\lambda_{oe}} - Z_{oe} \right)$$

DESCRIPTION	VALUE	UNIT
DEAD LOAD CALCULATION		
Floor Load @ 5.6 m Level		
Thickness of slab	0.15	M
Self Wt Of slab	0	T/Sqm
Grain Load	0.06	T/Sqm
Total Load	0.06	T/Sqm
LIVE LOAD CALCULATIONS		
Live load is taken as 500kg/Sqm at 5.6 m lvl	0.5	MT/Sqm
Live load is taken as 250kg/Sqm at 23.9 m lvl	0.25	MT/Sqm

PRESSURE CALCULATION ON BIN STATIC CONDITION RISE GRAIN		
For Cylindrical Portion		
Horizontal pressure due to static condition of rise		
Ph at Z from Top		
Ph =	$K_a \times \text{Density} \times Z$	
Where ,		
$K_a$	$= (1 - \text{SIN}\#) / (1 + \text{SIN}\#)$	0.2174

Density of rise	0.9	T/m3
Sample calculation		
Z	0.5	M
Ph for Z @ 0.5m	0.09783	

Dia Of Bunker	Height (From top of bin ) in "m"	Vertical Pressure(T/Pressure)	Horizontal Pressure at bin wall ( T/Sqm)
D	Z	Pv=yz	Ph=Pv*Ka
9.80	0.500	0.450	0.098
9.80	1.000	0.900	0.196
9.80	1.500	1.350	0.293
9.80	2.000	1.800	0.391
9.80	2.500	2.250	0.489
9.80	3.000	2.700	0.587
9.80	3.500	3.150	0.685
9.80	4.000	3.600	0.783
9.80	4.500	4.050	0.880
9.80	5.000	4.500	0.978
9.80	5.500	4.950	1.076
9.80	6.000	5.400	1.174
9.80	6.500	5.850	1.272
9.80	7.000	6.300	1.370
9.80	7.500	6.750	1.467
9.80	8.000	7.200	1.565

9.80	8.500	7.650	1.663
9.80	9.000	8.100	1.761
9.23	9.455	8.510	1.850
8.70	9.910	8.919	1.939
8.18	10.365	9.329	2.028
7.66	10.820	9.738	2.117
7.14	11.275	10.148	2.206
6.62	11.730	10.557	2.295
6.09	12.185	10.967	2.384
5.57	12.640	11.376	2.473
5.05	13.095	11.786	2.562
4.52	13.550	12.195	2.651
4.00	14.005	12.605	2.740

### V WIND LOAD

The wind load can be calculated using calculated using the Indian standards IS:875(Part 3)-1987. The basic wind speed corresponding to Chennai region is taken from the code IS:875 (Part 3)-1987. The design wind speed is modified to induce the effect of risk factor ( $k_1$ ), terrain coefficient ( $k_2$ ) and local topography ( $k_3$ ) to get the design wind speed  $V_z$ .

$$V_z = k_1 k_2 k_3 V_b$$

The design wind pressure  $P_z$  at any height above mean ground level is  $0.6V_z^2$ . The coefficient 0.6 in the above formula depends on a number of factors and mainly on the air temperatures.

$$P_z = 0.6V_z^2$$

Solidity ratio is defined as the ratio of effective area (projected area of all the individual elements) of a name normal to the wind direction divided by the area enclosed by the boundary of the name normal to the wind direction. Force coefficient for lattice towers of square or equilateral triangle section with flat sided members for wind blowing against any face shall be as given in Table 30 of IS:875(Part-3)-1987.

Force coefficients for lattice towers of square section with circular members and equilateral triangle section with circular members are as given in tables 31 and 32 of IS: 875(Part-3)-1987 respectively. Table 2 of IS:875(Pa1t-3)-1987 gives the factors to obtain design wind speed variation with height in different terrains for different classes of structures such as class( A,B,C ).

The wind load acting on a tower can be computed as  $F = C_{dt} A_e P_z k^2$ . The force coefficient depends upon the way in which the wind flows around it and is dependent upon the velocity and kinematic viscosity of the wind and diameter of the section, for circular sections. The force coefficient is generally quoted against a non-dimensional parameter, which is called the Reynolds number, which takes account of the velocity and viscosity of the medium and the member diameter. The tower is analyzed by following two conditions

- Wind Loads acting parallel to face
- Wind Loads acting parallel to face

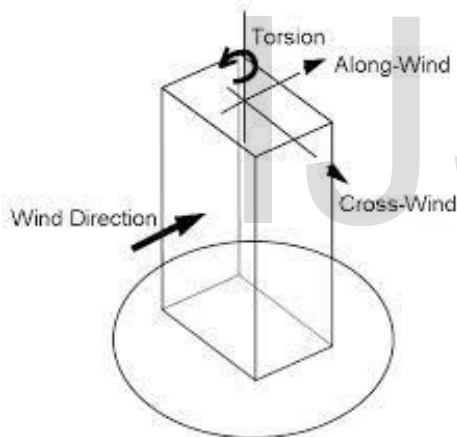

VII STAAD.Pro Analysis

6.1 Plan

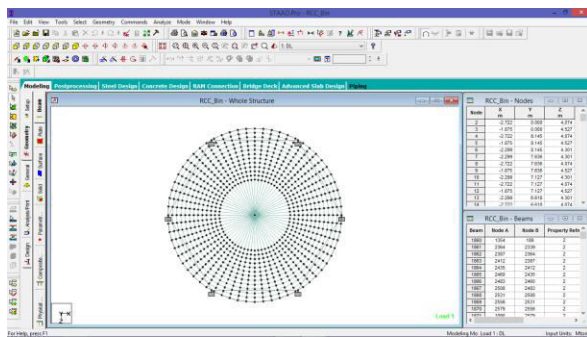

6.2 Node diagram

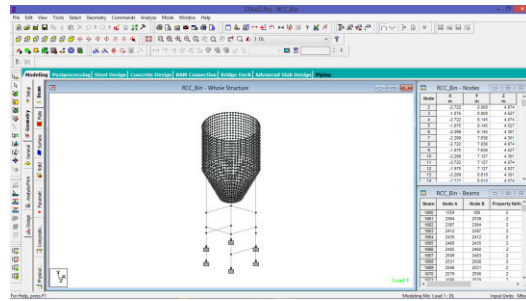

6.3 D.L

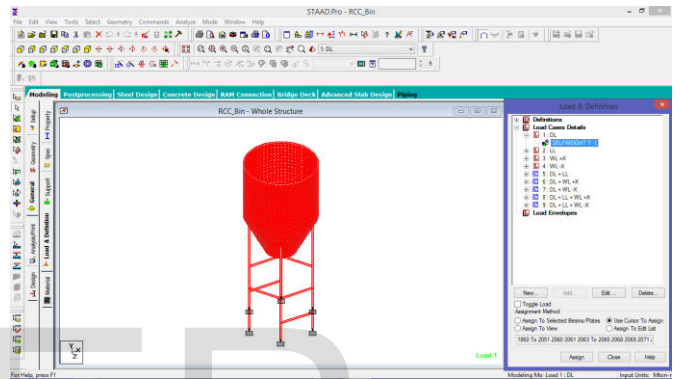

6.4 L.L

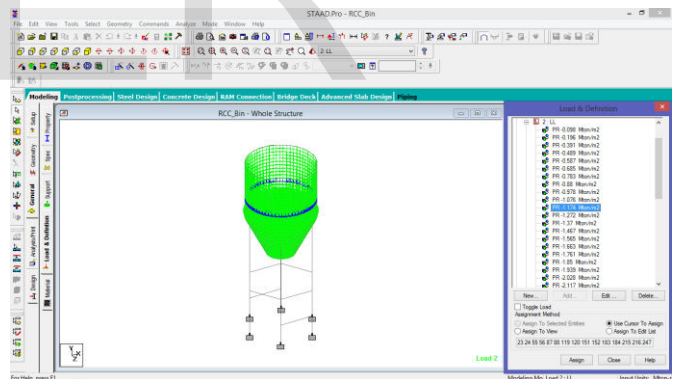

6.6 Wind load

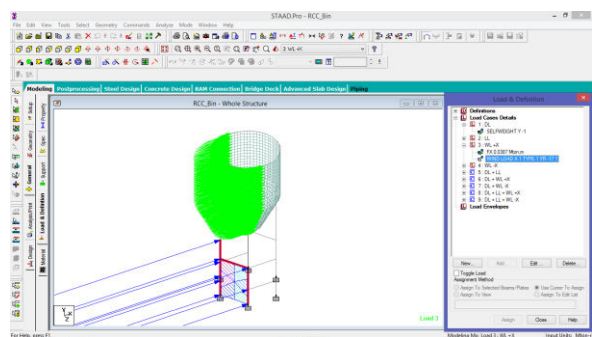

### 6.6 Load combination

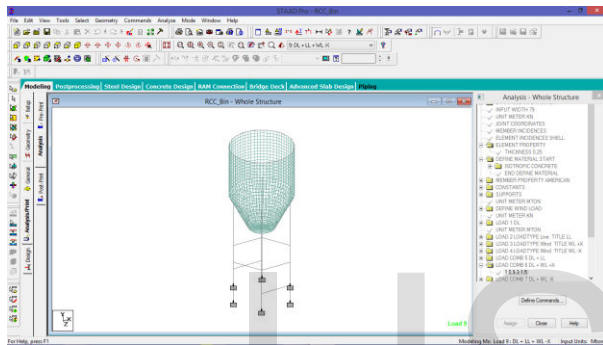
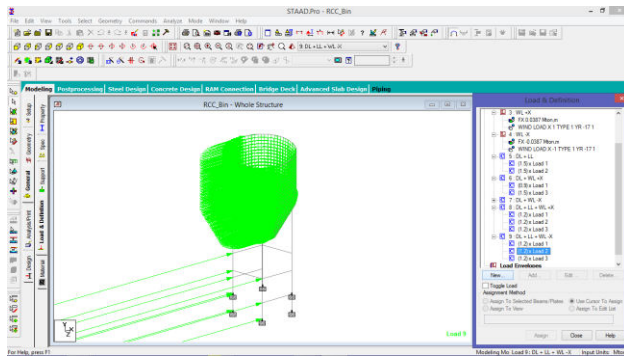

### VIII CONCLUSION

The design of bin performs an indispensable role in production technology. As per present strategy the storage of grain becomes, a vital part in Indian vegetarian diet. In this thesis, collected various literatures performed and based on the research comprehend the problem due to variation in pressure of storing materials in loading and unloading conditions also the analysis of whole structure to be carried out using STAAD.Pro software.

### REFERENCES

[1]. A. H. Askari and A. E. Elwi (1988). "Numerical Prediction of Hopper Bin Pressures".  
[2]. A. Lapko, J.A. Prusiel, "Studies on thermal actions and forces in cylindrical storage silo bins"  
[3]. Jamieson, H.A. (1903). Grain Pressures in Deep Bins.  
[4]. Jamieson, J.A. (1904). Grain Pressures in Deep Bins.

[5]. Jenike, A.W. (1961). Gravity Flow of Bulk Solids.  
[6]. Jenike, A.W. (1964). Storage and Flow of Solids.  
[7]. Jenike, A.W. and Johanson, J.R. (1969). On the Theory of Bin Loads.  
[8]. Jenike, A.W., Johanson, J.R. and Carson, J.W. (1973). Bin Loads - Part 2,3,4:  
[9]. J.G. Teng, J.M. Rotter, "Buckling of rings in column-supported bins and tanks"  
[10]. Johanson, J.R. (1964). Stress and Velocity Fields in the Gravity Flow of Bulk Solids.  
[11]. Mark E. Killion (1985). "Design Pressures in Circular Bins".  
[12]. Monasa, F., Abdel-Saved, G., and Siddal, W. (1985). "Cold-Formed Steell Farm Structures, Part I: Grain Bins."  
[13]. O.A. Khatchatourian, M.O. Binelo "Simulation of three-dimensional airflow in grain storage bins"  
[14]. Ooms, M. and Roberts. A.W. (1985). The Reduction and Control of Flow Pressures in Cracked Grain Silos. Bulk Solids Handling.  
[15]. P.A. MacDonald, K.C.S. Kwok, J.D. Holmes "Wind loads on circular storage bins and tanks: I. Point pressure measurements on isolated structures II. Effect of grouping"  
[16]. Ray Bucklin, Sid Thompson, Michael Montross, Ali Abdel-Hadi, "Grain Storage Bin Systems Design"  
[17]. R. A. Bucklin, S. A. Thompson, and I. J. Ross (1990). "Bin Wall Failure Caused by Eccentric Discharge of Free Flowing Grain"  
[18]. Xiapin Hua and Chris Letchford (2014) "A Comparison of Wind Loads on Circular Bins, Silos and Tanks"  
[19]. Y. T. Feng and Y. L. Hua (1996). "Modified Janssen Theory for Flexible Circular Bins."